

PM 1x2 Magnet Optical Switch

Characteristic

- No moving components
- The switching speed is fast
- Extremely stable latch mode
- Low power consumption
- Excellent stability and reliability

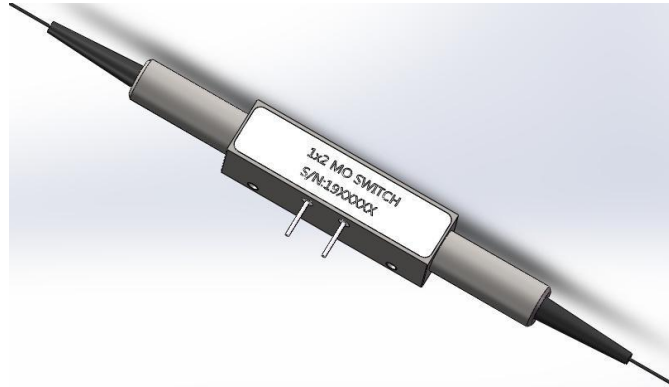

Application

- High speed protection
- System monitoring
- Test measurement
- Optical fiber sensing system

Product description

The 1x2 or 2x1 optical switch is a solid-state optical switch that does not have any moving components inside and is based on the Faraday effect. This series of products use the principle of electromagnetic induction and Faraday rotation effect to change the polarization state of the incident beam, combined with the use of birefringent

Parameter

Item	Unit	Parameters		Notes
		Unidirectional	Bidirectional	
Wavelength Range	nm	1525~1565		Other band optional
Insertion Loss	dB	0.8(Typ.);1.1(Max.)	0.8(Typ.);1.1(Max.)	
Return Loss	dB	≥40 (Typ 50)	≥40	
Cross-talk	dB	≥40 (Typ 50)	≥40	
ER	dB	≥18		
WDL	dB	≤0.3		
TDL	dB	≤0.3		
Repeatability	dB	+/- 0.01		
Durability	cycles	Regular (>100Billions) ; Ultra-fast(>1000Billions)		
Switching Speed	μs	Regular (50~200); Ultra-fast (5~20)		Other speed optional

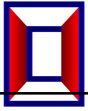

Operating Temperature	°C	-5~70	
Storage Temperature	°C	-40~85	
Maximum Optical Power	mW	500	High power optional
Dimension(L×W×H)	mm	32.8x8× 7	(With end cap 51.8x8x7)

Note:

1. All the specifications are based on the devices without connectors, and guaranteed over wavelength, polarization and temperature.
2. Specifications are subject to change without notice.

Mechanical dimension (mm)

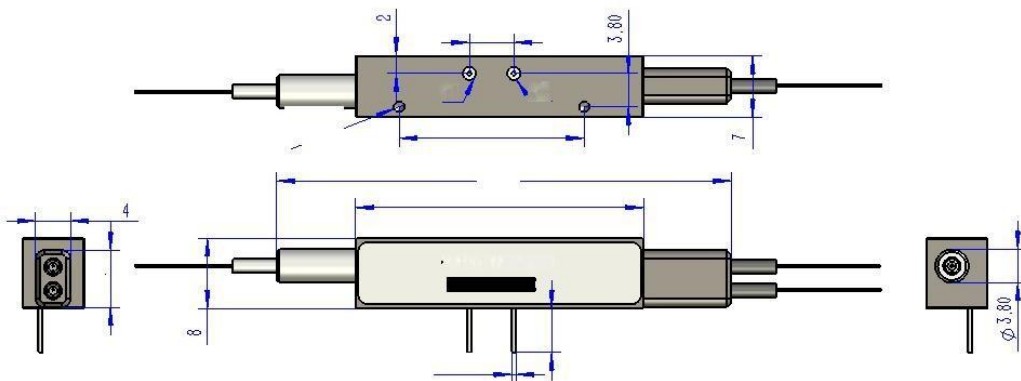

Electrical parameters

Parameters	Specifications		Unit
	Regular	Ultra-fast	
Switching Speed	50~200	5~20	μs
Switching Voltage (VCC)	3(+/-5%)	5~6	V
Switching Current	< 100	< 350	mA
Driving Mode	Voltage or Pulse Driving	Pulse Driving	NA
Pulse Width (typical)	1000	20	μs
Claim Frequency	<800	< 3000	Hz

Pin control definition Irreversible:

Pin1	Pin2	The Optical OutputPort
1(Voltage = VCC)	0(Voltage = GND)	IN→OUT1
0(Voltage = GND)	1(Voltage = VCC)	IN→OUT2

Reversible:

Pin1	Pin2	The Optical Output Port
1(Voltage = VCC)	0(Voltage = GND)	IN ↔OUT1
0(Voltage = GND)	1(Voltage = VCC)	IN ↔OUT2

Ordering Information HC- PMMS-A-B-C-D-E-F-G-H

PUM	A	B	C	D	E	F	G	H
S-								
	Working Mode	Switching Speed	Operating Wavelength	Axis Type	Fiber Tuber	Fiber Length	Fiber Type	Connector Type
	1. Regular 2. Bidirectional	1.50~200us 2.5~20us 3. Others	1.1525~1565 nm 2.1565-1615 nm 3. C & L Band 4. Others	1.B (Both of axis working) 3.F (Fast axis blocked)	1.250μm fiber 2. 900μm fiber 3. Others	1.0.5 +/- 0.1 m 2. 1.0 +/- 0.1 m 3. Others	1. PM98 2. PM15 3. PM13 4. Others	0.No Connector 1. FC/UPC 2. FC/APC 3. SC/UPC 4. SC/APC 5. LC/PC 6. MU/PC 7. Others