



Features

- Mini Size
- Fast Switch Speed
- Low Insertion Loss & PDL
- Wide Operating Wavelength Range
- High Reliability & Stability



Applications

- Network Monitor System
- Remote Fiber Testing System
- Module & System Integration
- Instrumentation

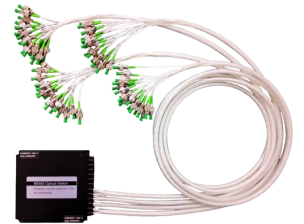

Compliance

- Telcordia GR-1221
- Telcordia GR-1073



Optical Path Diagram

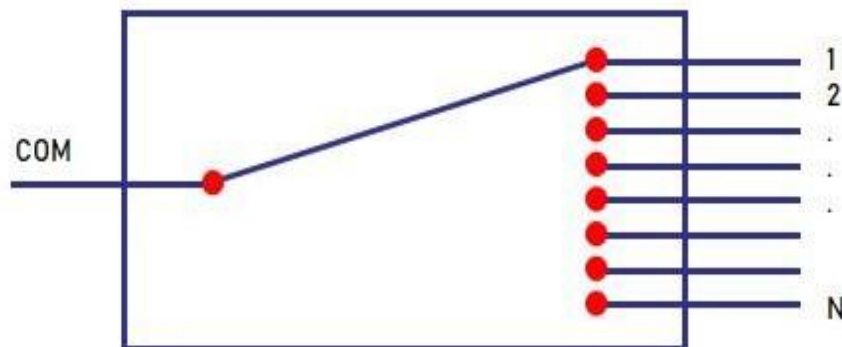



Technical Parameter

Single Mode

Parameters	Unit	MEMS 1×N-SM	
Working Wavelength	nm	O/C/L/L+ band	
Testing Wavelength	nm	1310/1550/1625/1650	
Insertion Loss	dB	@CWL Single-band	@CWL Dual-band
		≤0.8 (N≤8)	≤1.0 (N≤8)
		≤1.0 (8<N≤16)	≤1.2 (8<N≤16)
		≤1.3 (16<N≤32)	≤1.5 (16<N≤32)
		≤1.5 (32<N≤64)	≤1.7 (32<N≤64)
		≤2.0 (64<N≤144)	≤2.2 (64<N≤144)
		≤2.2 (144<N≤256)	≤2.4 (144<N≤256)
WDL	dB	≤0.3 (N≤64) ≤0.4 (64<N≤144) ≤0.5 (144<N≤256)	
PDL	dB	≤0.15	
Return Loss	dB	≥45	
Crosstalk	dB	≥50	
Repeatability	dB	≤±0.05	
Switching Time	ms	≤15	
Durability	times	≥10 ⁹	
Input Optical Power	mW	≤500	
Operating Voltage	V	DC 5V±10%	
Operating Current	mA	≤50 (N≤16)	
		≤250 (16<N≤64)	
		≤350 (64<N≤144)	
		≤500 (144<N≤256)	
Operating Temp.	°C	-20 ~ +85	
Storage Temp.	°C	-40 ~ +85	
Dimension (L×W×H)	mm	M1: 34×24×11 ±0.2 (N≤64, Bare Fiber) M2: 60×24×11 ±0.2 (N≤16, Loose Tube) M3: 90×55×12 ±0.2 (16<N≤64, Loose Tube) M4: 100×100×12 ±0.2 (64<N≤144, Loose Tube) M5: 110×141×12 ±0.2 (144<N≤256, Loose Tube)	

1. Within operating temperature and all SOP.
2. WDL is measured in a ±20nm range at 23°C.
3. Excluding connector.



Multi-Mode

Parameters	Unit	MEMS 1×N-MM	
Working Wavelength	nm	850±30, 1310±30	
Testing Wavelength	nm	850/1310	
Insertion Loss	dB	@CWL Single-band	@CWL Dual-band
		≤ 0.8 ($N \leq 12$) ≤ 1.0 ($12 < N \leq 16$) ≤ 1.8 ($16 < N \leq 128$)	≤ 1.0 ($N \leq 12$) ≤ 1.2 ($12 < N \leq 16$) ≤ 2.0 ($16 < N \leq 128$)
WDL	dB	≤ 0.3 ($N \leq 16$) ≤ 0.4 ($16 < N \leq 128$)	
PDL	dB	≤ 0.2	
Return Loss	dB	≥ 30	
Crosstalk	dB	≥ 30	
Repeatability	dB	$\leq \pm 0.05$	
Switching Time	ms	≤ 15	
Durability	times	$\geq 10^9$	
Input Optical Power	mW	≤ 500	
Operating Voltage	V	DC 5V±10%	
Operating Current	mA	≤ 50 ($N \leq 16$)	
		≤ 250 ($16 < N \leq 64$)	
		≤ 350 ($64 < N \leq 128$)	
Operating Temp.	°C	-20 ~ +85	
Storage Temp.	°C	-40 ~ +85	
Dimension (L×W×H)	mm	M1: 34×24×11 ±0.2 ($N \leq 16$, Bare Fiber) M2: 60×24×11 ±0.2 ($N \leq 16$, Loose Tube) M3: 90×55×12 ±0.2 ($16 < N \leq 64$, Loose Tube) M4: 100×100×12 ±0.2 ($64 < N \leq 128$, Loose Tube)	

1. Within Operating temperature and all SOP.
2. Excluding Connector
3. WDL is measured in a ±20nm range at 23°C



Dimension(mm)

M1: 34 × 24 × 11 mm

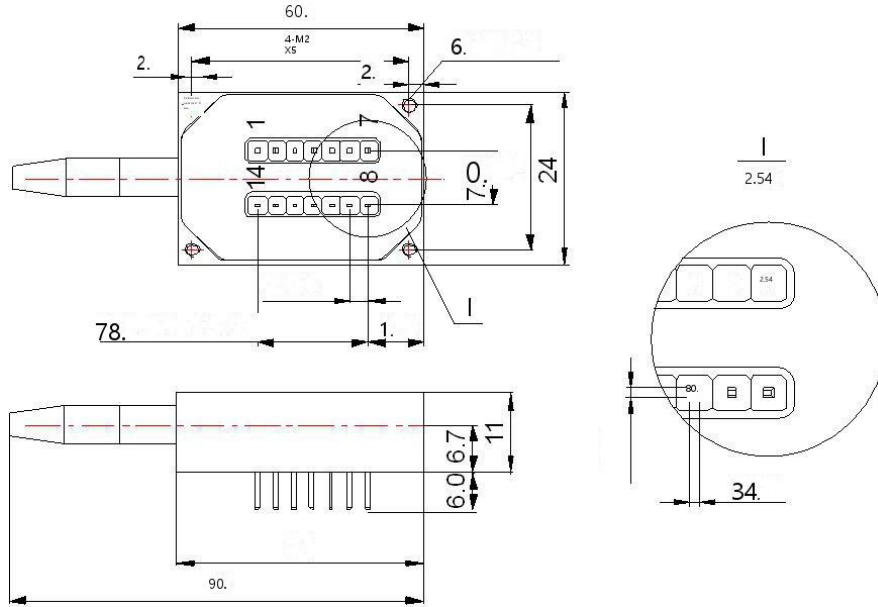

M2: 60 x 24 x 11 mm

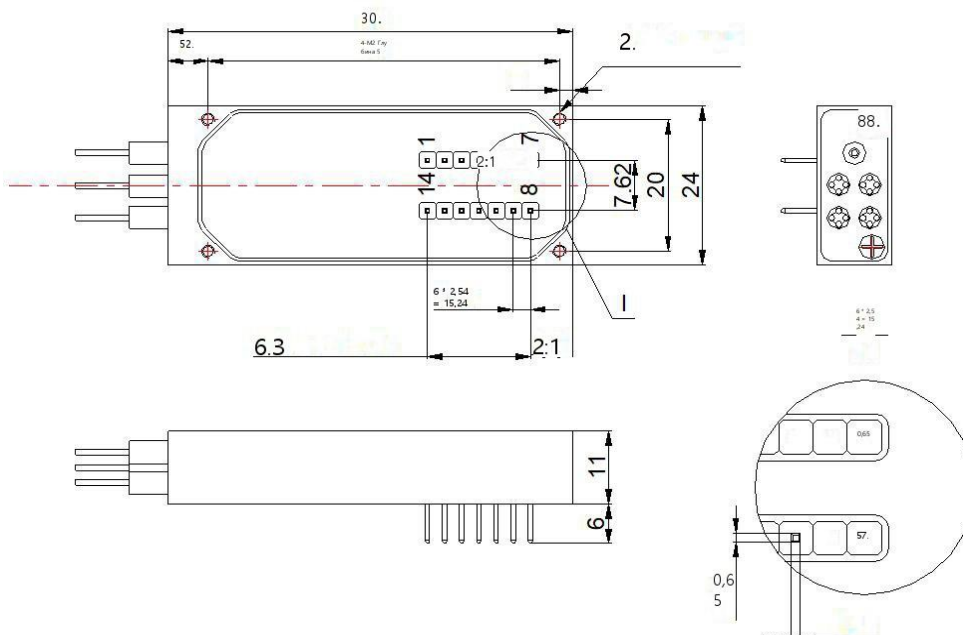



M3: 90 × 55 × 12 mm

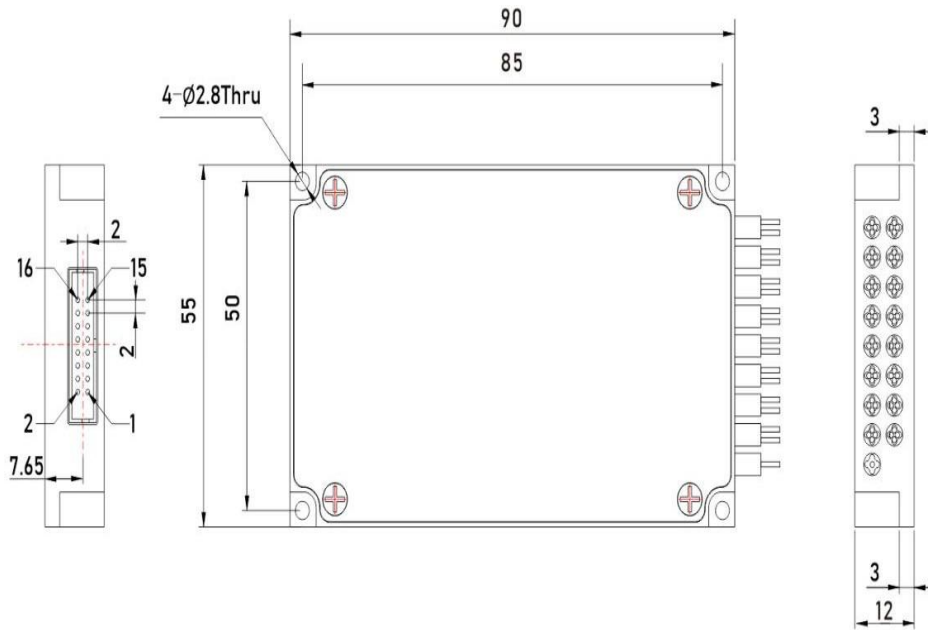

M4: 100 x100 x12 mm

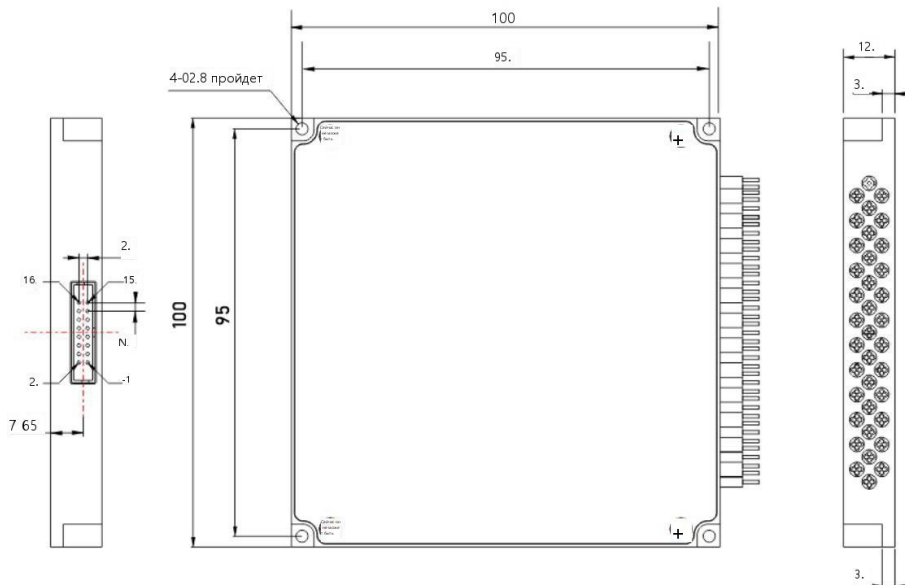



M5: 110 × 141 × 12 mm

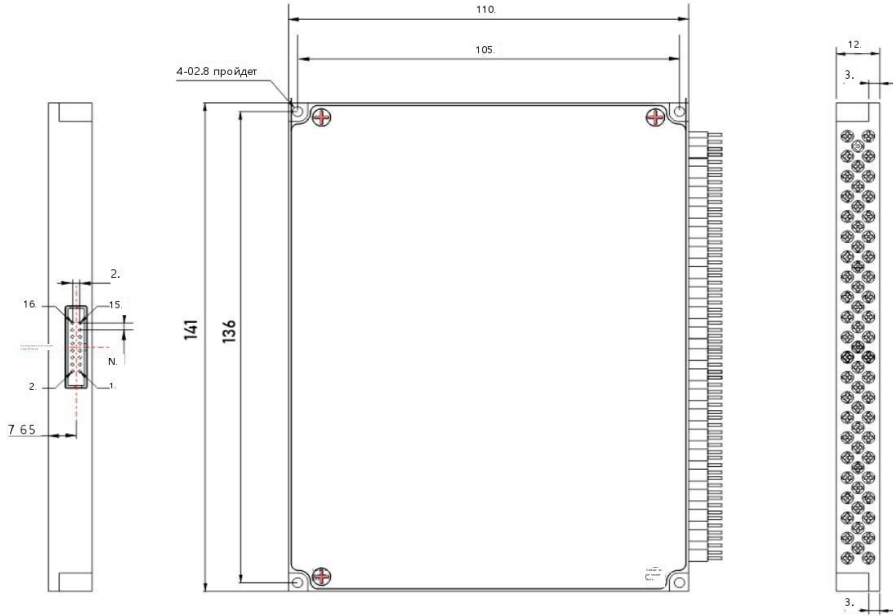

Pin Configurations

Pin No.		Pin Assignment	Signal Type	Description
M1/M2	M3/M4/M5			
5	1	D0	Input	Data bit (D0) (low-order)
	2	D5	Input	Data bit (D5)
2	3	VCC	Power	Power Supply (DC 5V,1.0A)
	4	D7	Input	Data bit (D7) (high-order)
	5	D6	Input	Data bit (D6)
4	6	GND	Power	GND
	7	D4	Input	Data bit (D4)
6	8	D1	Input	Data bit (D1)
9	9	TXD	Output	Data Transmit (TTL Level)
10	10	RXD	Input	Data Receive (TTL Level)
7	11	D2	Input	Data bit (D2)



8	12	D3	Input	Data bit (D3)
12	13	/BUSY	Output	Low level means ready to reset or receiving data
	14	/ALARM	Output	High level means running error
3	15	/STROBE	Input	Falling edge execution data bit
14	16	/RESET	Input	Low level reset to channel 0
11		GND	Power	GND
13		MODE		Low level: data bit control switch. High level: UART control switch
1		NC		No connection

Notes:

1. The electrical interfaces of M3, M4 and M5 modules is Molex 87833-1620. Molex 87568-1694 connector is recommended.
2. Only the serial port is available if the number of channels exceeds 16 when using M1 and M2.

 **Ordering Information: HC-MEMS-1xN-A-B-C-D-E-F-G**

A	B	C	D	E	F	G
Mode	Wavelength	Dimension	Fiber Type	Fiber Dimension	Fiber Length	Connector
S: SingleMode	85: 850nm	M1: 34×24×11	5:50/125	25:Φ0.25mm	05:0.5m	00:None
M: Multi-Mode	13:1310nm	M2: 60×24×11	6:62.5/125	90:Φ0.9mm	10:1.0m	FP:FCU/PC
	14:1490 nm	M3: 90×55×12	9:9/125	X:other	15:1.5m	FA:FC/APC
	15:1550 nm	M4: 100×100×12	X:other		X:other	SP:SC/UPC
	162:1625 nm					SA:SC/APC
	165:1650 nm	X:other				LP:LC/UPC
	13/15: 1310/1550 nm					LA:LC/APC
	X:other					MP:MPO
						X: other